

**BACRUFLEX**Al servicio de la minería,
pesquería e industria

Catálogo de productos

**VÁLVULAS
COMPUERTAS
BRIDADAS**

Gate Cast Steel A216 WCB Class 300

Body and Bonnet Cast Steel A216 WCB
 Bolted Bonnet
 Rising Stem OS&Y
 Design, Manufacture, Test in accordance with
 API 600
 Norm Steel Valves: ANSI/ASME B16.34
 Flange dimensions: ANSI/ASME B16.5 RF
 Face to Face dimensions: ANSI/ASME B16.10
 Hydrostatic Testing API 598
 Diameters: 2" to 24"

* Certification pending to norm API 600 from American
 Petroleum Institute

PRESSURE TEMPERATURE RATINGS

| Temperature °F/°C | Pressure worked lbs/inch ² (PSI) |
|--|--|
| | Class 300 |
| (-) 20 °F / (-) 29 °C to (+) 100 °F / (+) 38 °C | 740 |
| 200 °F / 93 °C | 675 |
| 300 °F / 149 °C | 655 |
| 400 °F / 204 °C | 635 |
| 500 °F / 260 °C | 600 |
| 600 °F / 316 °C | 550 |
| 650 °F / 343 °C | 535 |
| 700 °F / 371 °C | 535 |
| 750 °F / 399 °C | 505 |
| 800 °F / 427 °C | 410 |
| 850 °F / 454 °C | 270 |
| 900 °F / 482 °C | 170 |
| 950 °F / 510 °C | 105 |
| 1000 °F / 538 °C | 50 |





**Cast Steel A216 WCB
Class 300**

MATERIALS

| | PART NAME | MATERIAL |
|---|-----------|------------------------------|
| 1 | SEAT RING | ASTM A216 WCB+13% Cr |
| 2 | WEDGE | ASTM A216 WCB + 13% Cr |
| 3 | STEM | SS 410 |
| 4 | STUD | ASTM A193 B7 |
| 5 | NUT | ASTM A194 2H |
| 6 | GASKET | 13Cr /GRAPH. |
| 7 | PACKING | GRAPHITE |
| 8 | STEM NUT | ASTM A439 D-2 or ASTM B63 |

TEST API 598

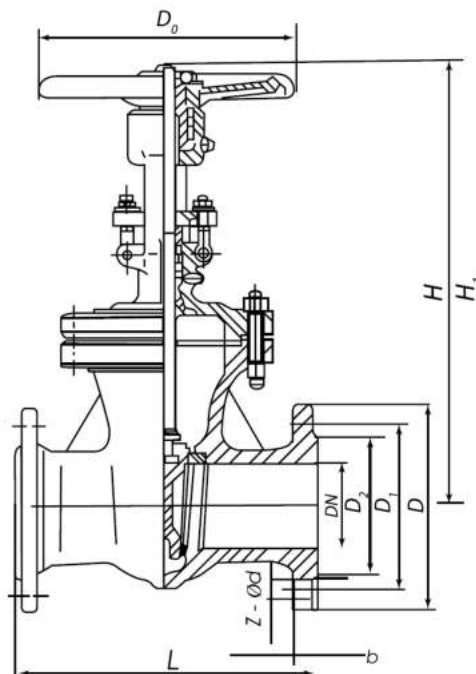

DIMENSIONS (mm)

| SIZE | L | D | D ₁ | D ₂ | B | Z-Ød | D ₀ | H | D ₁ | WEI-GHT (KG) |
|--------|------|-----|----------------|----------------|----|-------|----------------|------|----------------|--------------|
| 2" | 216 | 165 | 127 | 92 | 23 | 8-19 | 250 | 356 | 416 | 30 |
| 2 1/2" | 241 | 190 | 149 | 105 | 26 | 8-22 | 250 | 395 | 472 | 33 |
| 3" | 283 | 210 | 168.5 | 127 | 29 | 8-22 | 300 | 440 | 528 | 49 |
| 4" | 305 | 254 | 200 | 157 | 32 | 8-22 | 350 | 500 | 614 | 73 |
| 6" | 403 | 318 | 270 | 216 | 37 | 12-22 | 400 | 630 | 794 | 139 |
| 8" | 419 | 381 | 330 | 270 | 42 | 12-25 | 500 | 850 | 1064 | 225 |
| 10" | 457 | 445 | 387.5 | 324 | 48 | 16-29 | 600 | 1010 | 1264 | 343 |
| 12" | 502 | 521 | 451 | 381 | 51 | 16-32 | 650 | 1160 | 1475 | 475 |
| 14" | 762 | 584 | 514.5 | 413 | 54 | 20-32 | 650 | 1310 | 1662 | 693 |
| 16" | 838 | 648 | 571.5 | 470 | 58 | 20-35 | 650 | 1545 | 1946 | 1079 |
| 18" | 914 | 711 | 628.5 | 533 | 61 | 24-35 | 700 | 1623 | 2070 | 1232 |
| 20" | 991 | 775 | 686 | 584 | 64 | 24-35 | 700 | 1770 | 2270 | 1525 |
| 24" | 1143 | 914 | 813 | 692 | 70 | 24-41 | 800 | 2102 | 2710 | 2117 |